

NOTES:
 1) 175114 N₂ @ 20 psig
 2) STAINLESS STEEL (316) FITTINGS USED.

▲ DETCH FLOW DIRECTION IN AREA APPROXIMATELY SHOWN.

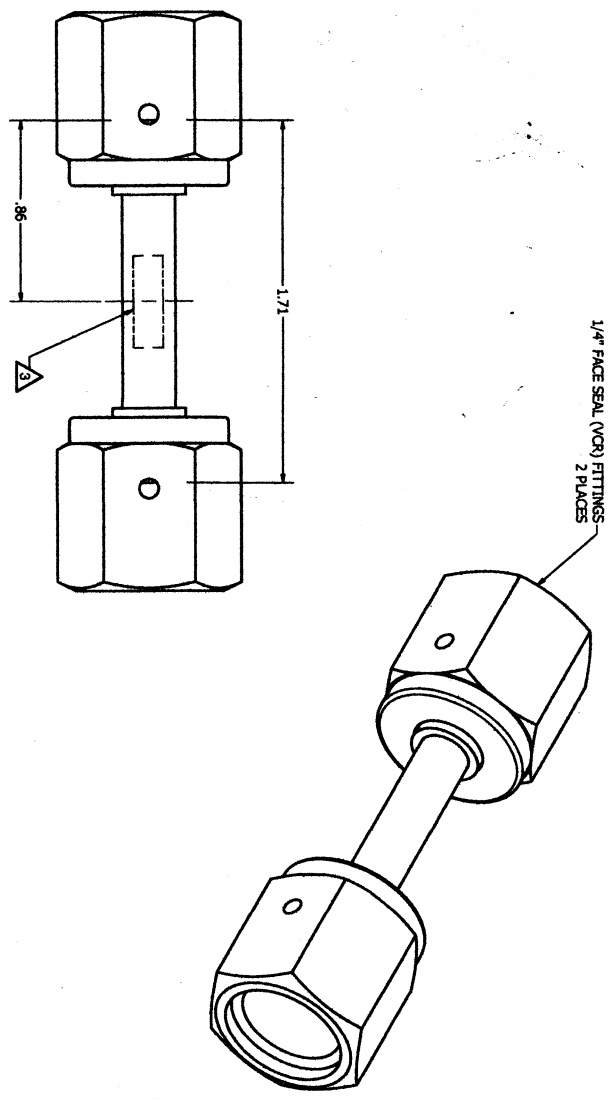

REVISION HISTORY			
REV	DESCRIPTION	DATE	APPROVED
A	INITIAL RELEASE	07/28/14	M.A.D.

THIS DOCUMENT IS THE PROPERTY OF COLLEMBUS TECH SOLUTIONS AND THE INFORMATION CONTAINED HEREIN IS UNCLASSIFIED EXCEPT WHERE SHOWN OTHERWISE. IT IS NOT TO BE USED, REPRODUCED, OR DISCLOSED IN ANY MANNER WITHOUT THE PRIOR WRITTEN PERMISSION OF COLLEMBUS TECH SOLUTIONS.		THIRD ANGLE PROJECTION	
UNLESS OTHERWISE SPECIFIED DIMENSIONS ARE IN INCHES PER ASME Y14.5-2009		APPROVALS	
TOLERANCES ARE: DECIMALS X ± .1 FRACTIONS XX ± .02 ANGLES ± .1 HOLES ± .010		DATE 7/8/2014	
FINISH DO NOT SCALE DRAWINGS		CHECK B. WITTEL	
DRAWN B. WITTEL		DATE 7/8/2014	
TITLE <i>Universal Micro Systems</i>		SIZE Dwg 1/8"	
UNION, B-A136-F5-22		SCALE NONE FILE: 008348-007_A.dwg	
SHEET 1 OF 1		REV A	